

WHEEL BLOCK SYSTEM

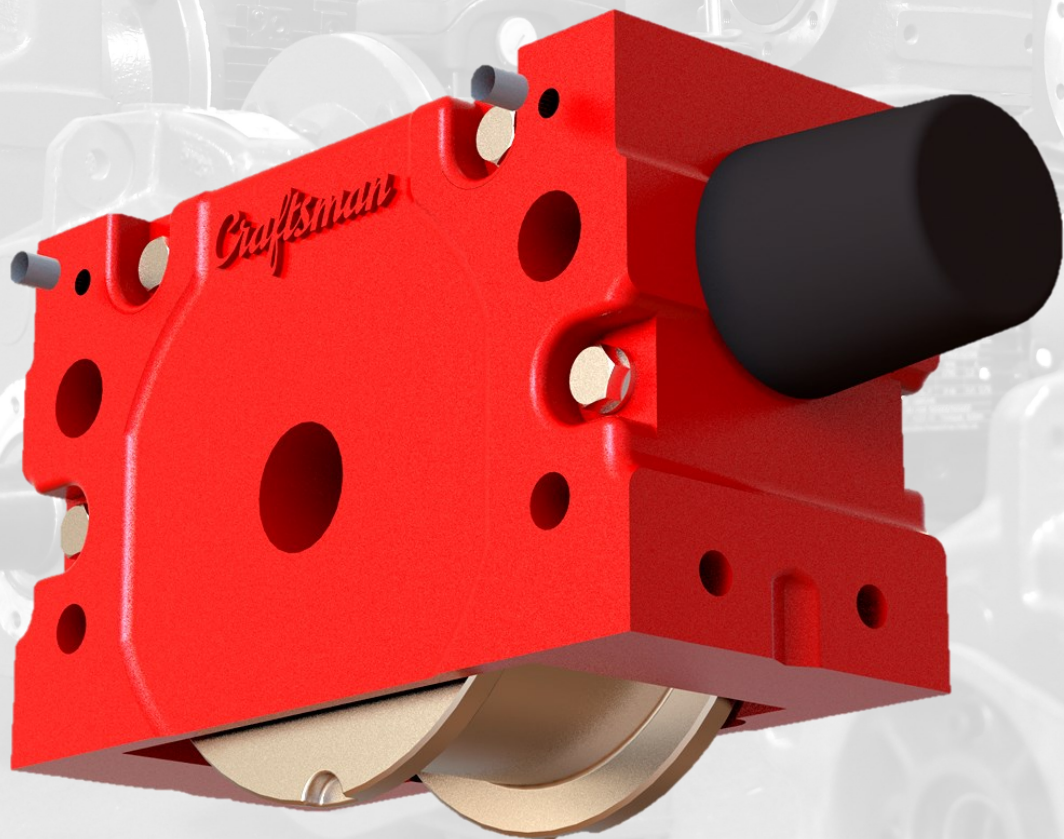

LIFT & CONNECT SAFELY

WWW.CARLSTAHL-CRAFTSMAN.COM

WHEEL BLOCK SYSTEM

CAPACITY RANGE UP TO 50 TONS



Craftsman Wheel Block are developed for unmatched performance and functional reliability by our team of experts & years of industry expertise. Modular wheel block system from Craftsman enables the fast and cost-effective solution to meet your individual requirements. CRWB Housing, Cover and Wheel was made of spheroidal graphite cast iron which ensures structural stability. Bearings are carefully selected to the suite with the practical load conditions and to have low maintenance. The wheel block systems are available in various load capacities which satisfies the fast-growing industrial requirements.

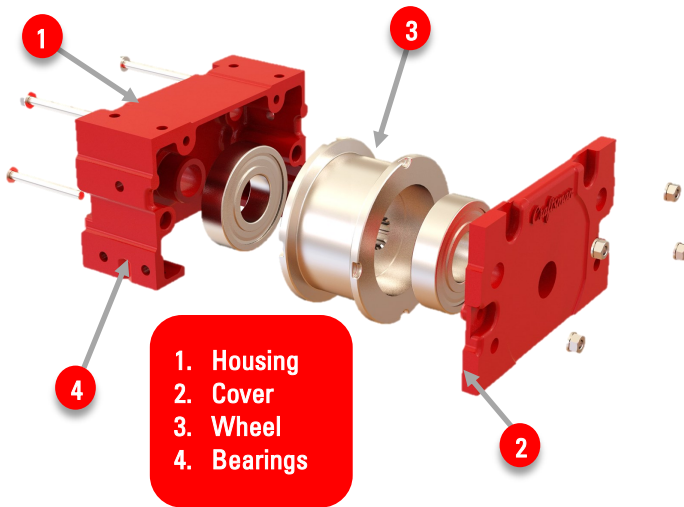

CRANE APPLICATION				
MODEL / WHEEL DIA	PIN CONNECTION	END CONNECTION	TOP CONNECTION	SIDE CONNECTION
CRWB 112*	✓	✓	✓	# OTHER APPLICATION
CRWB 125	✓	✓	✓	
CRWB 160	✓	✓	✓	
CRWB 200	✓	✓	✓	
CRWB 250	✓	✓	⊘	
CRWB 320	✓	⊘	⊘	
CRWB 400	✓	⊘	⊘	
CRWB 500*	✓	⊘	⊘	

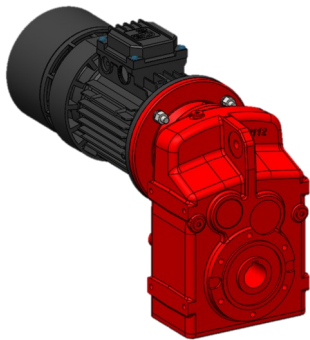

Craftsman Travel Drives consist of Parallel shaft helical gearbox and Electric motor which provides efficient and compact solution for Drives. Gears are made of case hardened alloy steel and profile corrected to ensure the maximum transmissible torque, gears and bearing are oil bath or splash lubricated which serve silent operation and improve the reliability of gears. Electric motors are 3 Phase induction type which conforming to latest IEC/IS standards.

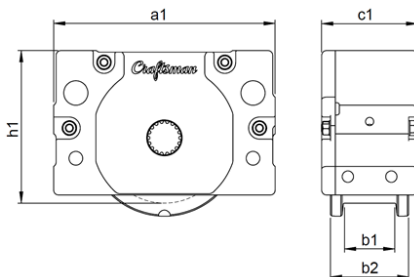

TECHNICAL DATA							
CRANE APPLICATION							
MODEL / WHEEL DIA	WEIGHT [KG]	DIMENSIONS (MM)					
		A1	B1 (MAX.)	B2	RAIL WIDTH	C1	H1
CRWB 112*	10.5	208	62	82	50	102	135
CRWB 125	12.5	230	62	82	50	102	151
CRWB 160	22.5	279	65	97	50	119	189
CRWB 200	38	340	82	114	75	136	244
CRWB 250	65.5	385	85	117	80	161	290
CRWB 320	117.5	470	85	125	80	190	362
CRWB 400	196	580	110	150	100	214	448
CRWB 500*	295	700	110	150	100	246	566

* - Order on request

WHEEL BLOCK SYSTEM

CAPACITY RANGE UP TO 50 TONS

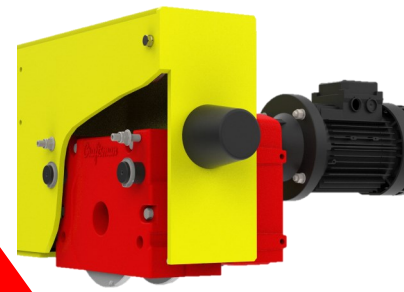

TYPES OF CONNECTION

TOP CONNECTION

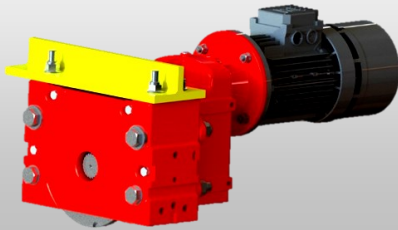

PIN CONNECTION

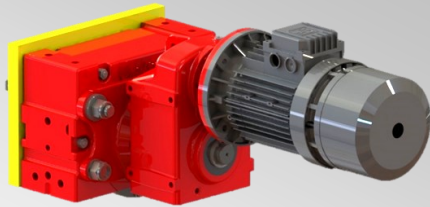
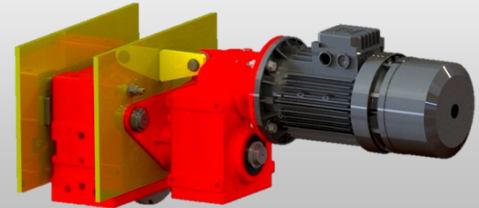

SIDE CONNECTION

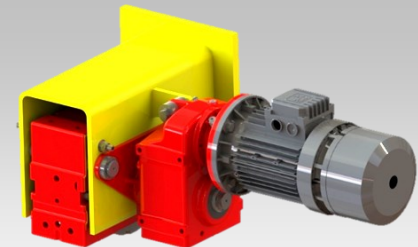

END CONNECTION

WHEEL BLOCK FEATURES

- For crane manufacturers, it provides a ready-made solutions.
- The wheels are totally machined, and made of spheroidal cast iron material SG-700/2
- Double flanged wheel for Wheel Block
- Grey iron housings ensure the robustness of the product
- Wheel flange wear indicator for easy inspection of wheel flange wear
- Ball / Taper roller bearings are used for very high service life.
- Center Mark in Housing makes the Span Setting easier in crane applications.
- Modular design to suit different mounting positions & applications.
- Easy dismantling & maintenance for Cranes & other applications.

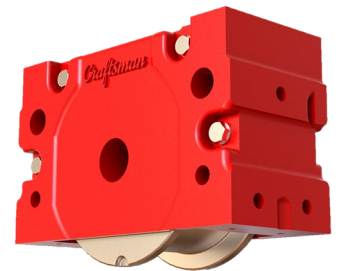

TRAVEL GEAR BOX

- Case hardened and Precision ground gears for smooth running and long life.
- Gears are permanently immersed in oil/grease for quiet, smooth and cool operation.
- Standard travelling speeds of 20, 30, 40 m/min at 50 Hz.
- Easy dismantling without removing Wheel Blocks.



TRAVEL MOTOR

- Heavy duty motor with an incorporated brake and fan cooling.
- The brake disc lining material is asbestos free with high friction coefficient and very long lasting.
- Provided with IP54 enclosure rating and F Class insulation.
- Suitable for 3 Phase, 415v $\pm 10\%$, 50Hz AC Supply.



APPLICATIONS

CRANE SYSTEMS

TRANSFER CARTS

LIFTING PLATFORMS

CONVEYING SYSTEM

LIFT & CONNECT SAFELY
WITH
CARL STAHL CRAFTSMAN



CARLSTAHL CRAFTSMAN ENTERPRISES PRIVATE LIMITED.

Registered Office,
No. 1078, Senthel Towers, 4th Floor
Avinashi Road
Coimbatore-641018
Tamilnadu, India

E-mail: sales@carlstahlcraftsman.com
Toll free number: 1800-121-12121